

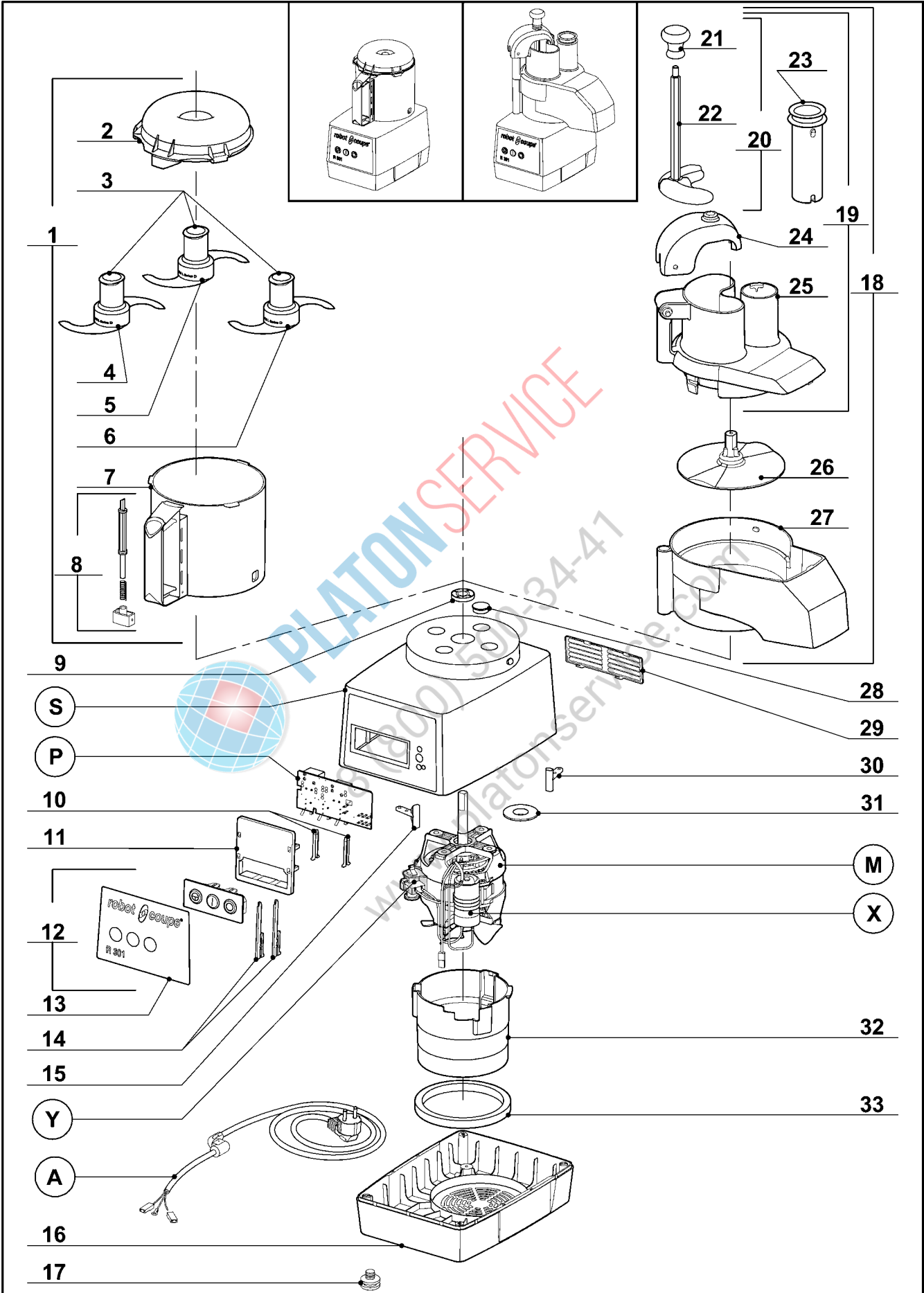

R 301 D

N° de série / Serial number
- 440 - - - - -



Index	Pièce / Part	Désignation	Description
1	27 272	CUTTER COMPLET	/ CUTTER ATTACHEMENT
2	117 395	COUVERCLE CUTTER	/ CUTTER LID
3	104 147	CAPUCHON COUTEAU	/ BLADE CAP
4	27 286	COUTEAU LISSE	/ STRAIGHT BLADE
5	27 287	COUTEAU DENTE	/ FINE SERRATED BLADE
6	27 288	COUTEAU CRANTE	/ SERRATED BLADE
7	104 434	ENSEMBLE CUVE CUTTER	/ CUTTER BOWL ASSEMBLY
8	39 227	ENS TIGE SECURITE	/ COMPLETE SAFETY ROD
9	501 010	BAGUE ETANCHEITE	/ MOTOR SEAL
10	102 913	CLAVETTE PLASTRON	/ PANEL KEY
11	102 911	SUPPORT PLATINE	/ PCB SUPPORT
12	39 290	ENS TABLEAU COMMANDE	/ SWITCH ASSEMBLY
13	407 833	PLAQUE FRONTALE	/ FRONT PLATE
14	117 703	CLAVETTE FIXE PLATINE	/ PCB KEY
15	29 441	ENS ILS CUTTER	/ CUTTER REED SWITCH ASSEMBLY
16	39 201	ENS SOCLE	/ BASE ASSEMBLY
17	101 082	PIED	/ FOOT
18	27 295	ENS COUPE LEGUMES	/ VEGETABLE SLICER ASSEMBLY
19	39 287	TETE COUPE LEGUMES COMPLETE	/ VEGETABLE SLICER HEAD
20	29 880	ENS POUSSOIR	/ PUSHER ASSEMBLY
21	102 021	POIGNEE	/ HANDLE KNOB
22	103 703	POUSSOIR LEGUME	/ VEGETABLE PUSHER
23	118 324	POUSSOIR CAROTTES	/ ROUND PUSHER
24	104 922	GUIDE POUSSOIR	/ PUSHER GUIDE
25	104 919	COUVERCLE COUPE LEGUMES	/ VEGETABLE SLICER LID
26	104 921	DISQUE EVACUATEUR	/ SLING PLATE
27	104 918	CUVE COUPE LEGUMES	/ VEGETABLE SLICER BOWL
28	104 070	CAPSULE CACHE VIS	/ BOLT COVER
29	104 122	GRILLE VENTILATION INOX	/ VENT COVER
30	29 356	ILS COMPLET COUPE LEGUMES	/ VEGETABLE REED SWITCH
31	104 078	CENTREUR MOTEUR	/ MOTOR CENTRING
32	104 110	CONDUIT VENTILATION	/ BAFFLE
33	101 099	TAMPON AMORTISSEUR	/ ABSORBER

Index	Pièce / Part	Désignation	/ Description				
A		CABLE D'ALIMENTATION	/ POWER CORD				
M		MOTEUR	/ MOTOR				
P		PLATINE	/ CIRCUIT BOARD				
X		CONDENSATEUR	/ CAPACITOR				
Y		RELAIS MOTEUR	/ MOTOR RELAY				
S		ENS. SUPPORT MOTEUR	/ MOTOR SUPPORT ASSEMBLY				
Machine	Voltage	A	M	P	X	Y	S
22 368	230/50/1	504 274	3 074	103 693	600 018	500 289	39 316
22 370 UK	240/50/1	504 275	3 074	103 693	600 018	500 289	39 289
22 371 Aust	240/50/1	504 278	3 074	103 693	600 018	500 289	39 316
22 372 DK	230/50/1	504 276	3 074	103 693	600 018	500 289	39 316
22 373	220/60/1	504 274	3 075	103 693	603 669	500 289	39 316
22 374	120/60/1	504 277	3 076	103 692	603 669	500 296	39 316
2 521 Pack 3D ALL	230/50/1	504 274	3 074	103 693	600 018	500 289	39 316
2 522 Pack 4D SWE	230/50/1	504 274	3 074	103 693	600 018	500 289	39 316
2 523 Pack 4D FR	230/50/1	504 274	3 074	103 693	600 018	500 289	39 316
2 524 Cutter	230/50/1	504 274	3 074	103 693	600 018	500 289	39 316
2 525 Cutter-CL	230/50/1	504 274	3 074	103 693	600 018	500 289	39 316
2 526 Pack 5D OST	230/50/1	504 274	3 074	103 693	600 018	500 289	39 316
2 527 DK	230/50/1	504 276	3 074	103 693	600 018	500 289	39 316
2 528 Cutter-CL	120/60/1	504 277	3 076	103 692	603 669	500 296	39 316
2 537 Cutter-CL	220/60/1	504 274	3 075	103 693	603 669	500 289	39 316
2 538 Aust	240/50/1	504 278	3 074	103 693	600 018	500 289	39 316
2 539 UK	240/50/1	504 275	3 074	103 693	600 018	500 289	39 289